

Atlas Copco angle battery tool

The industrial choice



DEKO TECH.

Tel: +98 21 4440 5248

Fax: +98 21 4385 1355

Mobile: +98 912 175 9529

E-mail: info@deko-co.com

Atlas Copco

A technician wearing safety glasses and a blue uniform with orange reflective stripes is using a yellow power drill to work on the interior of a car door. The car is silver and the door is open. The technician is focused on the task, and the background is a bright, clean workshop environment.

Battery Assembly Tools

Contents	Page
Introduction.....	74
BCP screwdriver, clutch type.....	76
BTV nutrunners, clutch type.....	78
Tensor STB nutrunner, transducerized type.....	81

True cordless freedom

Atlas Copco's range of industrial battery assembly tools includes both shut-off and transducerized nutrunners and screwdrivers. They allow maximum freedom of movement along the line and inside narrow or closed compartments. Tensor STB tools also offer advanced process control.

The main advantage of battery tools is their superior flexibility due to the absence of cables. This, in turn, improves the efficiency of the operator. Battery assembly tools also contribute to improving safety in the workplace, since there are no air hoses or electric cables to become entangled or jammed. Also, in the automotive industry, for instance, there is no risk of scratches on the car body finish from air hoses or electric cables.

BCP screwdrivers – a pleasure to work with

The BCP screwdriver is ideal for quality critical applications where flexibility is essential. The slim, well-balanced design and ergonomic pistol grip on the BCP screwdriver make it a pleasure to hold. Its compact size and Lithium-Ion batteries put it among the lightest battery screwdrivers on the market. BCP screwdrivers also offer variable speed and plenty of power, with torque levels ranging from 0.8 up to 12 Nm.

All these ergonomic features make the BCP screwdriver the kind of tool you can work with all day long.

BTV nutrunners – the durable and reliable angle tool choice

The BTV nutrunner is the cordless angle tool choice for quality critical applications in cramped spaces. The robust industrial design of the BTV nutrunner means durable and reliable operation with a service life that matches any other power tool. Yet it is lightweight and handy, giving the best operator comfort for tightening operations from 2 to 28 Nm. Torque accuracy has electronic precision thanks to the ACD (Acoustic Clutch Detection) control.

Tensor STB nutrunners – fast, light, transducerized battery tools

Ergonomically designed Tensor STB pistol-grip (up to 12 Nm) and angle nutrunners (up to 100 Nm) are ideal for safety critical applications in cramped areas. No other battery powered tool can match Tensor STB's unique fastening performance and advanced process control.

Atlas Copco Industrial Radio Communication (IRC) enables the Tensor STB to be partnered with a Power Focus controller for accurate torque monitoring and full joint traceability. At a typical workstation, one Tensor STB tool can be used for several applications within the same torque range.

A new member of the STB family is the STB Stand Alone, this tool is a standard STB but you will not need a controller (apart from when you set it up for the first time). Since you do not have a controller the STB will not report any values to the controller.



Powerful, durable and highly operator friendly

For quality critical applications where flexibility is essential, the BCP screwdriver and the BTV nutrunner are the ideal tool choices. Powerful and durable with superior ergonomics and operator feedback they offer higher productivity in assembly operations, independent of the industry.

Freedom – truly flexible assembly

- No product damage from cables or hoses
- No trip hazards from trailing cables
- No cable or hose management
- Speed setting functionality for the BCP
- Reversible battery pack

Power – high performance and durability

- Robust and industrial tool design
- Li-Ion battery technology for BCP: high power-to-weight.

Ergonomics – a pleasure to work with

- Reduced operator fatigue and work related health problems
- Light, compact and well-balanced design
- Operator feedback



BCP Tool key features

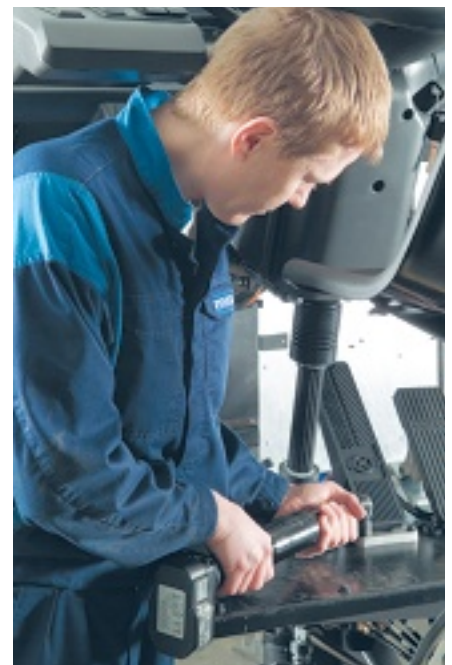

BTV Tool key features

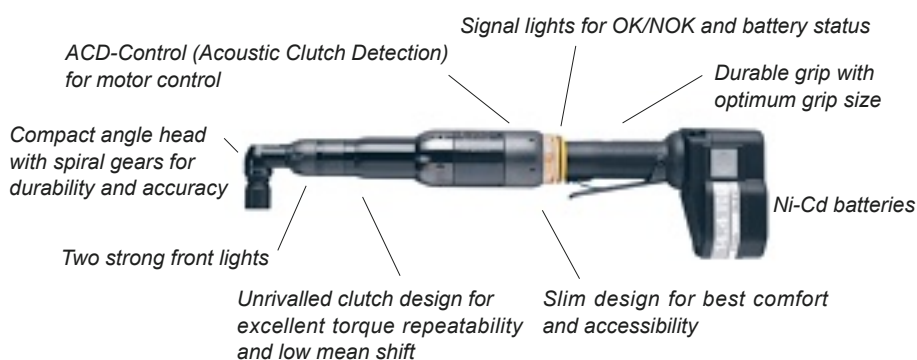

BCP screwdrivers offer true cordless freedom and superior ergonomics for the operator, thus contributing to outstanding performance.

- Ergonomic, lightweight pistol-grip design.
- 7 brushless models offering variable speed with a speed setting unit.
- Torque range: 0.8 – 12 Nm.
- Low speed models available.
- Choice of two 18 V Li-Ion batteries: 1.3 Ah Flat Pack or 2.6 Ah Big Pack.



Model	Square drive in	Torque		Speed r/min	Weight (excl. battery)		Length mm	Height mm	Ordering No.
		Nm	ft lb		kg	lb			
BCP BL2-I06	1/4	0.8-2.5	0.6-1.8	500 - 1550	0.86	1.89	200	188	8431 1273 00
BCP BL6-I06	1/4	2.0-6.0	1.5-4.4	300 - 1000	0.86	1.89	200	188	8431 1273 10
BCP BL8-I06	1/4	3.0-8.0	2.2-5.9	300 - 800	0.86	1.89	200	188	8431 1273 20
BCP BL12-I06	1/4	5.0-12.0	3.7-8.8	250 - 600	0.86	1.89	200	188	8431 1273 30
BCP BL-2L-I06	1/4	0.8-2.5	0.6-1.8	150 - 440	0.86	1.89	200	188	8431 1273 50
BCP BL-6L-I06	1/4	1.5-6.0	1.1-4.4	150 - 440	0.86	1.89	200	188	8431 1273 60
BCP BL-12L-I06	1/4	3.0-12.0	2.2-8.8	150 - 440	0.86	1.89	200	188	8431 1273 40

-L stands for low speed models.

NOTE: The tools are set at maximum speed at delivery.



DEKO TECH.

Tel: +98 21 4440 5248

Fax: +98 21 4385 1355

Mobile: +98 912 175 9529

E-mail: info@deko-co.com

Optional Accessories

Batteries

Model	Current V	Electric charge Ah	Weight		Charge time min	Ordering No.
			kg	lb		
Li-Ion flat pack	18	1.3	0.37	0.81	35	4211 5426 82
Li-Ion big pack	18	2.6	0.63	1.39	70	4211 5426 83

Battery
Flat pack.

Chargers

Model	V / Hz	Input/Output V / A	Weight		Ordering No.
			kg	lb	
EU-contact	230V / 50Hz	18V / 1.8A	0.61	1.34	4211 5428 80
UK-contact	230V / 50Hz	18V / 1.8A	0.61	1.34	4211 5428 81
BR-contact	230V / 60Hz	18V / 1.8A	0.61	1.34	4211 5428 83
US-contact	115V / 60Hz	18V / 1.8A	0.61	1.34	4211 5428 84

Battery
Big pack

Cover protections

Model	Ordering No.
Battery cover protection, Flat pack	4211 5601 00
Battery cover protection, Big pack	4211 5602 00
Tool cover protection	4211 5415 00

Battery charger
18 V.

Colour rings

Model	Ordering No.
Red	4211 5461 02
Orange	4211 5461 03
Green	4211 5461 04
Blue	4211 5461 05
White	4211 5461 06
Purple	4211 5461 07
Grey	4211 5461 08

Miscellaneous

Model	Ordering No.
Speed setting unit	4211 5462 80
Support handle	4211 5421 80
Suspension bail	4211 5600 00
Tool holder	4220 4335 80



Support handle

Battery cover
Flat pack

Colour rings



Suspension bail

Battery cover
Big pack

Speed setting unit



Tool holder



Tool cover

BTV nutrunners are durable and reliable and offer flexible assembly. A lightweight and handy tool for maximum operator comfort.

- Robust yet ergonomic angle tool.
- Torque range 2-28 Nm.
- Choice of four Ni-Cd batteries from 9.6 to 14.4 V.
- Theft protection (PROT) versions available.



Model	Screw size mm	Recommended torque range		Free speed			Weight		Tool only Ordering No.	PROT version tool only Ordering No.
				9.6 V r/min	12 V r/min	14.4 V r/min	excl. battery	kg		
BTV7i-6	M3-M5	2 - 7	18 - 62	350	450	–	1.4	3.0	8431 0261 40	8431 0261 52
BTV7i-42	M3-M5	2 - 7	18 - 62	350	450	–	1.4	3.0	8431 0261 44	8431 0261 53
BTV7i-Q	M3-M5	2 - 7	18 - 62	350	450	–	1.4	3.0	8431 0261 49	8431 0261 54
BTV11i-6	M4-M6	4 - 11	36 - 97	300	380	–	1.4	3.0	8431 0261 55	8431 0261 59
BTV11i-42	M4-M6	4 - 11	36 - 97	300	380	–	1.4	3.0	8431 0261 56	8431 0261 60
BTV11i-Q	M4-M6	4 - 11	36 - 97	300	380	–	1.4	3.0	8431 0261 57	8431 0261 61
BTV11i-10	M4-M6	4 - 11	36 - 97	300	380	–	1.4	3.0	8431 0261 58	8431 0261 64
BTV15i-6	M6	8 - 15	70 - 132	–	340	410	1.7	3.7	8431 0261 65	8431 0261 69
BTV15i-42	M6	8 - 15	70 - 132	–	340	410	1.7	3.7	8431 0261 72	8431 0261 76
BTV15i-Q	M6	8 - 15	70 - 132	–	340	410	1.7	3.7	8431 0261 73	8431 0261 77
BTV15i-10	M6	8 - 15	70 - 132	–	340	410	1.7	3.7	8431 0261 68	8431 0261 78
BTV28i-42	M8	15 - 28	132 - 248	–	210	260	1.8	4.0	8431 0261 79	8431 0262 10
BTV28i-10	M8	15 - 28	132 - 248	–	210	260	1.8	4.0	8431 0261 80	8431 0262 11
BTV28i-B10	M8	15 - 28	132 - 248	–	210	260	1.8	4.0	8431 0261 83	8431 0262 12
BTV28i-Q	M8	15 - 28	132 - 248	–	210	260	1.8	4.0	8431 0261 86	–
BTV28i-FS10	M8	15 - 28	132 - 248	–	210	260	1.8	4.0	8431 0261 89	–
BTV28i-FS13	M8	15 - 28	132 - 248	–	210	260	1.8	4.0	8431 0261 92	–

All pistol grip models have 1/4" female hexagon drive for bits with quick change chuck.



DEKO TECH.

Tel: +98 21 4440 5248

Fax: +98 21 4385 1355

Mobile: +98 912 175 9529

E-mail: info@deko-co.com

Optional Accessories

Batteries

Model	Voltage	Capacity	Weight gram	Ordering No.
BTV 7/11	9.6 V	2.0 Ah	570	4210 3680 02
BTV 15/28	14.4 V	2.0 Ah	800	4210 3680 06
All tools	12 V Flat pack	1.4 Ah	500	4210 3680 03
All tools	12 V	2.0 Ah	730	4210 3680 05



12 V Flat pack / 1.4 Ah



12 V / 2.0 Ah

Pulse charger

Model	Voltage	Capacity	Ordering No.
15/23 min	230/240 V	(1.4/2.0 Ah)	4210 3676 10
25/36 min	110/120 V	(1.4/2.0 Ah)	4210 3676 20
1/1.3 hour	230/240 V	(1.4/2.0 Ah)	4210 3676 00



14.4 V / 2.0 Ah



9.6 V / 2.0 Ah

Mounting bracket for multiple charger

Model	Voltage	Ordering No.
Euro-contact	230/240 V	4210 3677 00
US-contact	110/120 V	4210 3677 01

NOTE: Chargers are bought separately.



Decoder kit

Model	Voltage	Ordering No.
Decoder kit	230/240 V	4210 3679 90
Decoder kit	110/120 V	4210 3679 91

Pulse charger

Suspension yoke

Model	Ordering No.
BTV (swivelling)	4211 5080 80



Decoder

Cordless freedom with full process control

Tensor STB battery powered nutrunners offer the same benefits in terms of process control as Tensor ST nutrunners, yet with the freedom of cordless tools. The tools have the capability to communicate with a Power Focus controller, via IRC, for full process control.

Flexibility – no more cables

- No more cables and cable management
- No more damaged cables
- No product damage from cables
- No trip hazards from trailing cables

Productivity – save time

- Increased operator efficiency
- Easy to set up and replace
- Eliminate need for multiple operations
- Up to 100% faster than competing products

Ergonomics

- Reduced operator fatigue and work related health problems
- Unhindered access
- Low weight – up to 20 % lighter than competing products
- Compact size



STB Tool key features

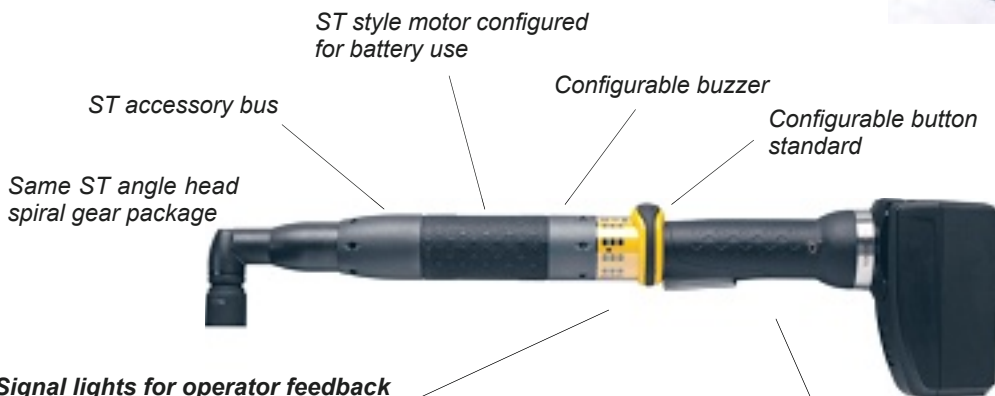

- Li-Ion battery package**
- 18V 2.6 Ah
 - 30V 2.6 Ah

Signal lights for operator feedback

- Tightening status
- Batch OK
- Battery status
- Communication status
- Tool events

Extremely compact electronics within the tool handle

Tensor STB offers genuine ergonomic and flexibility advantages for the operator which, in turn, raises operator efficiency.

- Low tool weight and high spindle speed reduce cycle time.
- Freedom of movement in all working positions.
- Lightweight components help reduce operator fatigue.
- Torque range ETV: 2-100 Nm.
- Torque range ETP: 2-12 Nm.
- STB is also available with ETO and ETC models.



Model	Square drive in	Torque		Battery	Speed r/min	Weight		Length mm	CS distance	Height mm	Ordering No.		
		Nm	ft lb			kg	lb						
Angle													
ETV STB32-10-10	3/8	2-10	2-7.5	Li-Io 18 V	943	1.3	2.9	1.9	4.2	406	11	41	8433 3010 20
ETV STB32-10-10-BCR	3/8	2-10	2-7.5	Li-Io 18 V	943	1.5	3.2	2.05	4.5	406	11	41	8433 3010 25
ETV STB32-10-B10	3/8	2-10	2-7.5	Li-Io 18 V	943	1.3	2.9	1.9	4.2	406	11	41	8433 3010 30
ETV STB32-10-B10-BCR	3/8	2-10	2-7.5	Li-Io 18 V	943	1.5	3.2	2.05	4.5	406	11	41	8433 3010 35
ETV STB32-15-10	3/8	4-15	3-11	Li-Io 18 V	720	1.3	2.9	1.9	4.2	406	11	41	8433 3010 82
ETV STB32-15-10-BCR	3/8	4-15	3-11	Li-Io 18 V	720	1.5	3.2	2.05	4.5	406	11	41	8433 3010 89
ETV STB32-15-B10	3/8	4-15	3-11	Li-Io 18 V	720	1.3	2.9	1.9	4.2	406	11	41	8433 3010 96
ETV STB32-15-B10-BCR	3/8	4-15	3-11	Li-Io 18 V	720	1.5	3.2	2.05	4.5	406	11	41	8433 3010 99
ETV STB32-20-10	3/8	5-20	4-14.5	Li-Io 18 V	480	1.4	3.08	1.99	4.41	440.3	14	41.8	8433 3011 05
ETV STB32-20-10-BCR	3/8	5-20	4-14.5	Li-Io 18 V	480	1.5	3.41	2.14	4.74	440.3	14	41.8	8433 3011 10
ETV STB32-20-B10	3/8	5-20	4-14.5	Li-Io 18 V	480	1.4	3.08	1.99	4.41	440.3	14	41.8	8433 3011 15
ETV STB32-20-B10-BCR	3/8	5-20	4-14.5	Li-Io 18 V	480	1.5	3.41	2.14	4.74	440.3	14	41.8	8433 3011 20
ETV STB32-30-10	3/8	6-30	4.5-22	Li-Io 18 V	380	1.5	3.3	2.1	4.6	444	14	41.8	8433 3011 66
ETV STB32-30-10-BCR	3/8	6-30	4.5-22	Li-Io 18 V	380	1.6	3.6	2.2	4.9	444	14	41.8	8433 3011 69
ETV STB32-30-B10	3/8	6-30	4.5-22	Li-Io 18 V	380	1.5	3.3	2.1	4.6	444	14	41.8	8433 3011 76
ETV STB32-30-B10-BCR	3/8	6-30	4.5-22	Li-Io 18 V	380	1.6	3.6	2.2	4.9	444	14	41.8	8433 3011 79
ETV STB62-30-10	3/8	6-30	4.5-22	Li-Io 30 V	610	1.75	3.85	2.65	5.8	466	14	41.8	8433 3030 21
ETV STB62-30-10-BCR	3/8	6-30	4.5-22	Li-Io 30 V	610	1.9	4.2	2.8	6.2	466	14	41.8	8433 3030 28
ETV STB62-30-B10	3/8	6-30	4.5-22	Li-Io 30 V	610	1.75	3.85	2.65	5.8	466	14	41.8	8433 3030 36
ETV STB62-30-B10-BCR	3/8	6-30	4.5-22	Li-Io 30 V	610	1.9	4.2	2.8	6.2	466	14	41.8	8433 3030 38
ETV STB62-40-10	3/8	12-40	9-29	Li-Io 30 V	465	1.7	3.8	2.55	5.7	479	18	47	8433 3031 22
ETV STB62-40-10-BCR	3/8	12-40	9-29	Li-Io 30 V	465	1.9	4.1	2.75	6.1	479	18	47	8433 3031 28
ETV STB62-40-B10	3/8	12-40	9-29	Li-Io 30 V	465	1.7	3.8	2.55	5.7	479	18	47	8433 3031 39
ETV STB62-40-B10-BCR	3/8	12-40	9-29	Li-Io 30 V	465	1.9	4.1	2.75	6.1	479	18	47	8433 3031 48
ETV STB62-50-10	3/8	15-50	10-37	Li-Io 30 V	375	1.7	3.8	2.55	5.7	479	18	47	8433 3032 67
ETV STB62-50-10-BCR	3/8	15-50	10-37	Li-Io 30 V	375	1.9	4.1	2.75	6.1	479	18	47	8433 3032 68
ETV STB62-50-B10	3/8	15-50	10-37	Li-Io 30 V	375	1.7	3.8	2.55	5.7	479	18	47	8433 3032 75
ETV STB62-50-B10-BCR	3/8	15-50	10-37	Li-Io 30 V	375	1.9	4.1	2.75	6.1	479	18	47	8433 3032 78
ETV STB62-70-13	1/2	15-70	10-50.7	Li-Io 30 V	265	2.3	5.1	3.2	7.1	492	20	58	8433 3033 05
ETV STB62-70-13-BCR	1/2	15-70	10-50.7	Li-Io 30 V	265	2.5	5.4	3.35	7.4	492	20	58	8433 3033 10
ETV STB62-70-B13	1/2	15-70	10-50.7	Li-Io 30 V	265	2.3	5.1	3.2	7.1	492	20	58	8433 3033 15
ETV STB62-70-B13-BCR	1/2	15-70	10-50.7	Li-Io 30 V	265	2.5	5.4	3.35	7.4	492	20	58	8433 3033 20
ETV STB62-100-13	1/2	20-100	15-72.5	Li-Io 30 V	170	2.9	6.4	3.8	8.4	528.5	22.5	60.5	8433 3034 05
ETV STB62-100-13-BCR	1/2	20-100	15-72.5	Li-Io 30 V	170	3.1	6.73	3.95	8.71	528.5	22.5	60.5	8433 3034 10
ETV STB62-100-B13	1/2	20-100	15-72.5	Li-Io 30 V	170	2.9	6.4	3.8	8.4	528.5	22.5	60.5	8433 3034 15
ETV STB62-100-B13-BCR	1/2	20-100	15-72.5	Li-Io 30 V	170	3.1	6.73	3.95	8.71	528.5	22.5	60.5	8433 3034 20
Pistol grip													
ETP STB32-06-10	3/8	2-6	2-4	Li-Io 18 V	1500	0.9	2	1.5	3.3	218	-	186	8433 3110 25
ETP STB32-06-10-BCR	3/8	2-6	2-4	Li-Io 18 V	1500	1	2.3	1.6	3.5	218	-	186	8433 3110 28
ETP STB32-06-I06	1/4	2-6	2-4	Li-Io 18 V	1500	0.9	2	1.5	3.3	218	-	186	8433 3110 37
ETP STB32-06-I06-BCR	1/4	2-6	2-4	Li-Io 18 V	1500	1	2.3	1.6	3.5	218	-	186	8433 3110 38
ETP STB32-12-10	3/8	4-12	3-9	Li-Io 18 V	750	0.9	2	1.5	3.3	218	-	186	8433 3111 35
ETP STB32-12-10-BCR	3/8	4-12	3-9	Li-Io 18 V	750	1	2.3	1.6	3.5	218	-	186	8433 3111 38
ETP STB32-12-I06	1/4	4-12	3-9	Li-Io 18 V	750	0.9	2	1.5	3.3	218	-	186	8433 3111 48
ETP STB32-12-I06-BCR	1/4	4-12	3-9	Li-Io 18 V	750	1	2.3	1.6	3.5	218	-	186	8433 3111 58

In-Line crowfoot tools

Dimensions

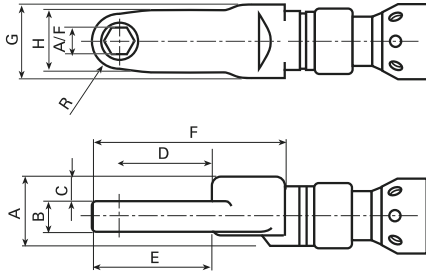

ETC STB

Model	Torque		Speed r/min	Weight		Length mm	A/F mm	A mm	B mm	C mm	D mm	E mm	F mm	G mm	H mm	R mm	Ordering No.
	Nm	ft lb		kg	lb												
ETC STB62																	
ETC STB62-18-10-LI3	4-18	3-13	470	2.4	5.2	470	10	34	15	13	47	59	82	35	22	10	8433 2316 11
ETC STB62-23-12-LI3	9-28	6-20	226	2.4	5.2	470	12	34	15	13	59	71	94	35	30	13	8433 2316 17
ETC STB62-28-12-LI3	9-28	6-20	226	2.4	5.2	470	12	34	15	13	59	71	94	35	30	13	8433 2316 14

Offset crowfoot tools

Dimensions

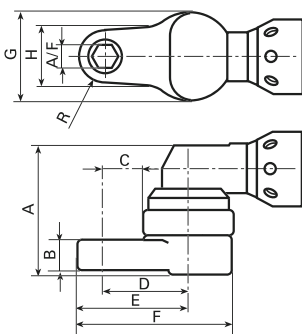

ETC STB

Model	Torque		Speed r/min	Weight		Length mm	A/F mm	A mm	B mm	C mm	D mm	E mm	F mm	G mm	H mm	R mm	Ordering No.
	Nm	ft lb		kg	lb												
ETC STB62																	
ETC STB62-18-10-LO3	5-18	4-13	610	3.85	8.5	495	10	60.3	15	17	33	43	58	37	22	10	8433 2315 09
ETC STB62-20-13-LO5	5-20	4-15	610	2.25	5	568	13	57	10	72	94	108	129	44	31	14	8433 2315 15
ETC STB62-28-12-LO5	9-28	7-20	465	2.27	5	558	12	69.5	15	62	84	97	118	44	30	13	8433 2315 12
ETC STB62-40-14-LO3	12-40	9-29	375	2.2	4.9	522	14	69.5	18	25	47	61	82	44	31	14	8433 2315 18
ETC STB62-40-3/8-LO3	12-40	9-29	375	2.4	5.2	512	10	90.3	36	18	40	51	71	44	29	10	8433 2315 24
ETC STB62-50-16-LO3	11-50	8-39	265	2.9	6.4	538	16	77.8	24	27	51	66	89	48	30	15	8433 2315 27

In-Line tube nut tools

Dimensions

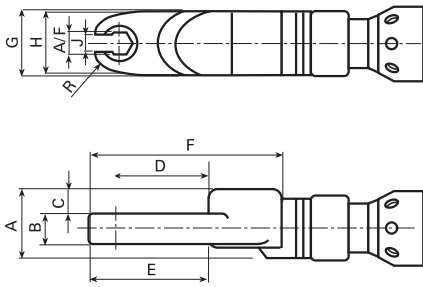

Model	Torque		Speed r/min	Weight		Length mm	A/F mm	A mm	B mm	C mm	D mm	E mm	F mm	G mm	H mm	J mm	R mm	Ordering No.
	Nm	ft lb		kg	lb													
ETO STB62																		
ETO STB62-8-8-LI3	3-8	2-6	945	2.3	5.1	446	8	32	11	12	31	22	60	34	-	6	8	8433 2316 53
ETO STB62-12-8-LI3	4-12	3-13	723	2.3	5.1	453	8	32	10	13	37	25	66	34	-	7	11	8433 2316 56
ETO STB62-15-10-LI3	6-15	5-11	589	2.3	5.1	454	10	32	12	11	38	26	68	34	-	8	14	8433 2316 62

Offset tube nut tools

Dimensions

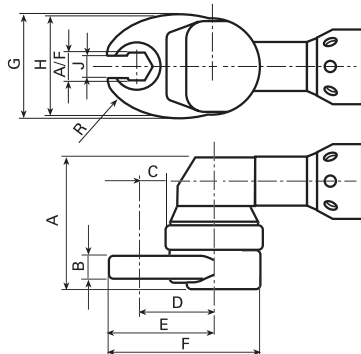

Model	Torque		Speed r/min	Weight		Length mm	A/F mm	A mm	B mm	C mm	D mm	E mm	F mm	G mm	H mm	J mm	R mm	Ordering No.
	Nm	ft lb		kg	lb													
ETO STB32																		
ETO STB32-12-10-LO5	4-12	3-9	480	1.8	3.9	495	10	62	10	43	70	71	86	37	31	7	11	8433 2315 66
ETO STB32-15-10-LO3	4-15	3-11	480	1.7	3.7	460	10	63	12	7	25	36	51	37	31	7	11	8433 2315 63
ETO STB62																		
ETO STB62-18-12-LO5	4-18	3-13	610	2.3	5	533	12	65	14	47	70	80	102	44	41	8	14	8433 2315 75
ETO STB62-20-12-LO3	5-20	3-15	610	2.2	4.7	492	12	64	14	7	29	40	61	44	41	8	14	8433 2315 72
ETO STB62-30-13-LO5	10-30	7-22	375	2.4	5.2	550	13	72.5	18	53	75	89	110	44	-	10	25	8433 2315 81
ETO STB62-30-13-LO3	9-30	7-22	465	2.2	4.7	513	13	65	11	13	37	52	74	50	-	10	31	8433 2315 84
ETO STB62-40-17-LO5	10-40	7-29	265	3.2	7.1	578	17	80	18	29	91	107	129	50	-	12	31	8433 2315 87
ETO STB62-50-17-LO3	12-50	9-37	265	3.1	6.9	537	17	73.8	12	18	49	69	97	59	-	16	32	8433 2315 90
ETO STB62-50-21-LO3	12-50	9-37	265	3.1	6.9	537	21	73.8	12	18	49	69	97	59	-	16	32	8433 2315 93

Optional Accessories

Chargers

Chargers	Voltage	Region	Ordering No.
18 V	230V/50Hz	EU	4211 5428 80
18 V	230V/50Hz	UK	4211 5428 81
18 V	115V/60Hz	US	4211 5428 84
18 V	230V/60V	BRA	4211 5428 83
30 V	230V/50Hz	EU	4211 5424 80
30 V	230V/50Hz	UK	4211 5424 81
30 V	120V/60Hz	US	4211 5424 84
30 V	230V/60V	BRA	4211 5424 83

Battery – Li-Io

Voltage	Capacity	Weight kg	Ordering No.
18 V	2.6 Ah	0.60	4211 5426 83
30 V	2.6 Ah	0.85	4211 5426 86

Controller software

Controller software	Ordering No.
RBU-Bronze	8433 0010 10
RBU-Silver	8433 0015 20
RBU-Gold	8433 0020 20

Controller hardware

Model	Ordering No.
Power Focus 4000	
PF 4000-G-HW	8433 6100 00
PF 4000-C-HW	8433 6100 05
PF 4000-G-DN-HW	8433 6140 00
PF 4000-C-DN-HW	8433 6140 05
PF 4000-C-FLN-HW	8433 6141 05
PF 4000-G-PB-HW	8433 6142 00
PF 4000-C-PB-HW	8433 6142 05
PF 4000-G-IB-HW	8433 6145 00
PF 4000-C-IB-HW	8433 6145 05
PF 4000-G-MB-HW	8433 6147 00
PF 4000-C-MB-HW	8433 6147 05
PF 4000-G-EIP-HW	8433 6149 00
PF 4000-C-EIP-HW	8433 6149 05
IRC FOCUS-B-G-HW*	8433 6500 00
IRC FOCUS-B-C-HW*	8433 6500 02

*) IRC Focus Communication kit is not needed. The IRC Focus is specially designed for the Tensor STB. The main benefit, except for all PF4000 advantages, is that the external access point is built into the IRC Focus. The IRC Focus cannot be used together with Atlas Copco cable tools.

ToolsTalk PF

No. of users	Ordering No.
Basic version W7	
1-user license	8092 1183 01
5-user license	8092 1183 05
10-user license	8092 1183 10
Plant license	8092 1183 99
Basic version W10	
1-user license	8092 1190 01
5-user license	8092 1190 05
10-user license	8092 1190 10
Plant license	8092 1190 99
Upgrade from W7 to W10	
1-user license	8092 1190 31
5-user license	8092 1190 35
10-user license	8092 1190 40
Plant license	8092 1190 49
Communication kit, (minimum PF SW 7.5) (Includes: Serial port adapter, I/O cable and 3 m serial cable.)	8433 3900 20

	Ordering No.
Operator panel advanced	8433 0565 00
Stacklight ESL04	8433 0570 13
Parameter Set Selector	8433 0616 05
Barcode Scanner	8433 0615 10
I/O Device module	8433 0617 12
Adjustable headlights	4220 3292 94
Level trigger 135°	4220 3311 90
Level trigger on top	4220 3186 90
Front button	4220 3184 90
Selector 4	8433 0610 04
Scanner protection	4220 2762 10
Protective cover	4220 2744 04
ETP Tool holder	4220 3584 80
Battery protection (18V)	4211 5602 00
Battery protection (30V)	4211 5444 00



Stacklight ESL-04



Operator panel advanced



Barcode scanner



Parameter set selector



Selector 4



I/O device module



Scanner protection



Battery cover 18 V, 2.6 Ah.



Battery cover 30 V, 2.6 Ah.



Protective cover Tensor ST



Adjustable headlight



Front trigger button



Lever trigger 135 deg.



Lever trigger top



Tool holder



DEKO TECH.

Tel: +98 21 4440 5248

Fax: +98 21 4385 1355

Mobile: +98 912 175 9529

E-mail: info@deko-co.com